

Approval body for construction products
and types of construction

Bautechnisches Prüfamt

An institution established by the Federal and
Laender Governments



European Technical Assessment

**ETA-11/0452
of 23 May 2016**

English translation prepared by DIBt - Original version in German language

General Part

Technical Assessment Body issuing the
European Technical Assessment:

Deutsches Institut für Bautechnik

Trade name of the construction product

HECO-UNIX-plus and HECO-UNIX-top screws

Product family
to which the construction product belongs

Self-tapping screws for use in timber constructions

Manufacturer

HECO-Schrauben GmbH & Co. KG
Dr.-Kurt-Steim-Straße 28
78713 Schramberg
DEUTSCHLAND

Manufacturing plant

HECO-Schrauben GmbH & Co. KG
Dr. Kurt-Steim-Straße 28
78713 Schramberg

This European Technical Assessment
contains

19 pages including 3 annexes which form an integral part
of this assessment

This European Technical Assessment is
issued in accordance with Regulation (EU)
No 305/2011, on the basis of

European Assessment Document (EAD)
130118-00-0603

This version replaces

ETA-11/0452 issued on 6 December 2011

The European Technical Assessment is issued by the Technical Assessment Body in its official language. Translations of this European Technical Assessment in other languages shall fully correspond to the original issued document and shall be identified as such.

Communication of this European Technical Assessment, including transmission by electronic means, shall be in full. However, partial reproduction may only be made with the written consent of the issuing Technical Assessment Body. Any partial reproduction shall be identified as such.

This European Technical Assessment may be withdrawn by the issuing Technical Assessment Body, in particular pursuant to information by the Commission in accordance with Article 25(3) of Regulation (EU) No 305/2011.

Specific part

1 Technical description of the product

HECO-UNIX-plus and HECO-UNIX-top screws are screws made from special carbon steel or stainless steel. Screws made from carbon steel are hardened. They have a corrosion protection according to Annex A.2.6. The outer thread diameter is not less than 3.5 mm and not greater than 6.0 mm. The overall length of the screws is ranging from 16 mm to 300 mm. Further dimensions are shown in Annex 3.

2 Specification of the intended use in accordance with the applicable European Assessment Document

The performances given in Section 3 are only valid if the HECO-UNIX-plus and HECO-UNIX-top screws are used in compliance with the specifications and conditions given in Annex 1 and 2.

Durability is only ensured if the specifications of intended use according to Annex 1 and 2 are taken into account.

The verifications and assessment methods on which this European Technical Assessment is based lead to the assumption of a working life of the HECO-UNIX-plus and HECO-UNIX-top screws of at least 50 years. The indications given on the working life cannot be interpreted as a guarantee given by the producer, but are to be regarded only as a means for choosing the right products in relation to the expected economically reasonable working life of the works.

3 Performance of the product and references to the methods used for its assessment

3.1 Mechanical resistance and stability (BWR 1)

Essential characteristic	Performance
Dimensions	See Annex 3
Characteristic yield moment	See Annex 2
Characteristic withdrawal parameter	See Annex 2
Characteristic head pull-through parameter	See Annex 2
Characteristic tensile strength	See Annex 2
Characteristic yield strength	No performance determined
Characteristic torsional strength	See Annex 2
Insertion moment	See Annex 2
Spacing, end and edge distances of the screws and minimum thickness of the wood based material	See Annex 2
Slip modulus for mainly axially loaded screws	See Annex 2

3.2 Safety in case of fire (BWR 2)

Essential characteristic	Performance
Reaction to fire	The screws are made of steel classified as Euroclass A1 in accordance with EC decision 96/603/EC, as amended by EC decision 2000/605/EC.

3.3 Hygiene, health and the environment (BWR 3)

Essential characteristic	Performance
Content, emission and/or release of dangerous substances	The product does not contain cadmium.

3.4 Safety and accessibility in use (BWR 4)

Same as BWR 1

3.5 Protection against noise (BWR 5)

Not applicable

3.6 Energy economy and heat retention (BWR 6)

Not applicable

3.7 Sustainable use of natural resources (BWR 7)

For the sustainable use of natural resources no performance was investigated for this product.

4 Assessment and verification of constancy of performance (AVCP) system applied, with reference to its legal base

In accordance with EAD No. 130118-00-0603, the applicable European legal act is: 97/176/EC.
The system to be applied is: 3

5 Technical details necessary for the implementation of the AVCP system, as provided for in the applicable EAD

Technical details necessary for the implementation of the AVCP system are laid down in the control plan deposited with Deutsches Institut für Bautechnik.

Issued in Berlin on 23 May 2016 by Deutsches Institut für Bautechnik

Andreas Kummerow
Head of Department

beglaubigt:
Dewitt

Annex 1 Specifications of intended use

A.1.1 Use of the HECO-UNIX-plus and HECO-UNIX-top screws only for:

- Static and quasi-static loads

A.1.2 Base materials

The self-tapping screws are used for connections in load bearing timber structures between wood-based members or between those members and steel members:

- Solid timber (softwood) according to EN 14081-1¹,
- Glued laminated timber (softwood) according to EN 14080²,
- Laminated veneer lumber LVL (softwood) according to EN 14374³, arrangement of the screws only at an angle α of $60^\circ \leq \alpha \leq 90^\circ$ to the plane of the veneers, where α is the angle between screw axis and the plane of the veneer,
- Glued solid timber (softwood) according to EN 14080 or national provisions that apply at the installation site,
- Cross-laminated timber (softwood) according to European Technical Approvals/ Assessments or national provisions that apply at the installation site.

The screws may be used for connecting the following wood-based panels to the timber members mentioned above:

- Plywood according to EN 636⁴ and EN 13986⁵,
- Oriented Strand Board, OSB according to EN 300⁶ and EN 13986,
- Particleboard according to EN 312⁷ and EN 13986,
- Fibreboards according to EN 622-2⁸, EN 622-3⁹ and EN 13986,
- Cement-bonded particle boards according to EN 634-2¹⁰ and EN 13986,
- Solid-wood panels according to EN 13353¹¹ and EN 13986.

Wood-based panels shall only be arranged on the side of the screw head.

1	EN 14081-1:2005+A1:2011	Timber structures – Strength graded structural timber with rectangular cross section – Part 1: General requirements
2	EN 14080:2013	Timber structures - Glued laminated timber and glued solid timber - Requirements
3	EN 14374:2004	Timber structures - Structural laminated veneer lumber - Requirements
4	EN 636:2012+A1:2015	Plywood - Specifications
5	EN 13986:2004+A1:2015	Wood-based panels for use in construction - Characteristics, evaluation of conformity and marking
6	EN 300:2006	Oriented strand boards (OSB) – Definition, classification and specifications
7	EN 312:2010	Particleboards - Specifications
8	EN 622-2:2004	Fibreboards – Specifications – Part 2: Requirements for hardboards
9	EN 622-3:2004	Fibreboards - Specifications - Part 3: Requirements for medium boards
10	EN 634-2:2007	Cement-bonded particleboards – Specifications – Part 2: Requirements for OPC bonded particleboards for use in dry, humid and external conditions
11	EN 13353:2011+A1:2011	Solid wood panels (SWP) – Requirements

HECO-UNIX-plus and HECO-UNIX-top screws	Annex 1
Specifications of intended use	

A.1.3 Use Conditions (environmental conditions)

The corrosion protection of the HECO-UNIX-plus and HECO-UNIX-top screws is specified in Annex A.2.6. With regards to the use and the environmental conditions, the national provisions of the place of installation apply.

A.1.4 Installation provisions

EN 1995-1-1¹² in conjunction with the respective National Annex applies for the installation.

The screws are either driven into the wood-based member made of softwood without pre-drilling or in pre-drilled holes with a diameter according to Table A.1.

Table A.1 Diameter of the pre-drilled holes in softwood

Outer thread diameter d [mm]	Diameter of the pre-drilled hole with a tolerance of ± 0.1 mm [mm]
	Softwood
3,5	2,0
4,0	2,5
4,5	3,0
5,0	3,0
6,0	4,0

The screw holes in steel members shall be pre-drilled with an adequate diameter greater than the outer thread diameter.

A minimum of two screws shall be used for connections in load bearing timber structures. This does not apply for special situations specified in National Annexes to EN 1995-1-1.

Only one screw may be used in structural connections when the minimum penetration length of the screw is $20 \cdot d$, the screw is only axially loaded and the angle between screw axis and grain direction is $\alpha \geq 15^\circ$. The load-bearing capacity of the screw shall be reduced by 50 %. If the screw is used as tensile reinforcement of timber structures perpendicular to the grain no reduction of the load-bearing capacity of the screw is required.

By fastening screws in wood-based members the head of the screws shall be flush with the surface of the wood-based member. For raised countersunk, cylinder and pan head the head part k respectively f remains unconsidered.

¹² EN 1995-1-1:2004+A1:2008+A2:2014

Eurocode 5: Design of timber structures – Part 1-1: General - Common rules and rules for buildings

HECO-UNIX-plus and HECO-UNIX-top screws	Annex 1
Installation provisions	

ANNEX 2 – Characteristic values of the load-carrying capacities

Table A.2.1 Characteristic load-carrying capacities of HECO-UNIX-plus and HECO-UNIX-top screws

Outer thread diameter [mm]		3.5	4.0	4.5	5.0	6.0
Characteristic yield moment $M_{y,k}$ [Nm]	Carbon steel	2.3	2.8	4.5	5.9	9.5
	Stainless steel	-	-	3.7	4.9	-
Characteristic tensile strength $f_{tens,k}$ [kN]	Carbon steel	3.4	4.4	5.6	7.9	11.3
	Stainless steel	-	-	5.3	7.4	-
Characteristic torsional strength $f_{tor,k}$ [Nm]	Carbon steel	2.1	2.9	4.5	6.2	11.0
	Stainless steel	-	-	4.1	6.0	-

A.2.1 General

The minimum penetration length of the threaded part of the screw l_{ef} shall be

$$l_{ef} = \min \left\{ \begin{array}{l} \frac{4 \cdot d}{\sin \alpha} \\ 20 \cdot d \end{array} \right.$$

where

- α angle between screw axis and grain direction
- d outer thread diameter of the screw.

The outer thread diameter of screws inserted in cross-laminated timber shall be at least 6 mm. To connect cross-laminated timber the inner thread diameter d_1 of the screws shall be greater than the maximal width of the gaps in the layer.

A.2.2 Laterally loaded screws

A.2.2.1 General

The outer thread diameter d shall be used as effective diameter of the screw according to EN 1995-1-1.

The embedding strength for the screws in wood-based members or in wood-based panels shall be taken from EN 1995-1-1 or from national provisions that apply at the installation site unless otherwise specified in the following.

HECO-UNIX-plus and HECO-UNIX-top screws	Annex 2
Characteristic values of the load-carrying capacities	

A.2.2.2 Solid timber, glued laminated timber and glued solid timber

The embedding strength for screws in non-pre-drilled holes in softwood arranged at an angle between screw axis and grain direction of $0^\circ \leq \alpha \leq 90^\circ$ is:

$$f_{h,k} = \frac{0.082 \cdot \rho_k \cdot d^{-0.3}}{2.5 \cdot \cos^2 \alpha + \sin^2 \alpha} \quad (2.1)$$

The embedding strength for screws in pre-drilled holes in softwood arranged at an angle between screw axis and grain direction of $0^\circ \leq \alpha \leq 90^\circ$ is:

$$f_{h,k} = \frac{0.082 \cdot \rho_k \cdot (1 - 0.01 \cdot d)}{2.5 \cdot \cos^2 \alpha + \sin^2 \alpha} \quad (2.2)$$

where

ρ_k Characteristic density of the wood-based member, for LVL $\rho_k \leq 500 \text{ kg/m}^3$

d Outer thread diameter of the screw [mm]

α Angle between screw axis and grain direction, $0^\circ \leq \alpha \leq 90^\circ$.

A.2.2.3 Cross laminated timber

The embedding strength for screws arranged in the edge surfaces parallel to the plane of cross laminated timber may be assumed according to equation (2.3) independent of the angle between screw axis and grain direction, $0^\circ \leq \alpha \leq 90^\circ$:

$$f_{h,k} = 20 \cdot d^{-0.5} \text{ in N/mm}^2 \quad (2.3)$$

unless otherwise specified in the technical specification of the cross laminated timber.

Where d is the outer thread diameter of the screws in mm.

Equation (2.3) is only valid for softwood layers. The provisions in the European Technical Approval/ Assessment or in national provisions of the cross laminated timber apply.

The embedding strength for screws in the wide face of cross laminated timber should be assumed as for solid timber based on the characteristic density of the outer layer. Where applicable, the angle between force and grain direction of the outer layer shall be taken into account. The direction of the lateral force shall be perpendicular to the screw axis and parallel to the wide face of the cross laminated timber.

A.2.3 Axially loaded screws

The axial slip modulus K_{ser} of the threaded part of a screw for the serviceability limit state per side shall be taken independent of angle α to the grain as:

$$K_{ser} = 780 \cdot d^{0.2} \cdot l_{ef}^{0.4} \quad [\text{N/mm}] \quad (2.4)$$

where

d outer thread diameter of the screw [mm]

l_{ef} penetration length of the of the threaded part of the screw in the wood-based member [mm].

HECO-UNIX-plus and HECO-UNIX-top screws	Annex 2
Characteristic load-bearing capacity values	

A.2.3.1 Axial withdrawal capacity

The characteristic withdrawal capacity in solid timber, glued laminated timber, cross laminated timber or laminated veneer lumber members made from softwood at an angle of $0^\circ \leq \alpha \leq 90^\circ$ to the grain shall be calculated as:

$$F_{ax,\alpha,Rk} = n_{ef} \cdot k_{ax} \cdot f_{ax,k} \cdot d \cdot l_{ef} \cdot \left(\frac{\rho_k}{350} \right)^{0.8} \quad (2.5)$$

where

$F_{ax,\alpha,Rk}$ Characteristic withdrawal capacity of a screw group at an angle α to the grain [N]

n_{ef} Effective number of screws according to EN 1995-1-1:2008, clause 8.7.2 (8)

For inclined screws with an angle between shear plane and screw axis $30^\circ \leq \alpha \leq 60^\circ$:

$$n_{ef} = \max \left\{ n^{0.9}; 0.9 \cdot n \right\} \quad (2.6)$$

For inclined screws as fasteners in mechanically jointed beams or columns or for the fixing of thermal insulation material, $n_{ef} = n$.

n Number of screws acting together in a connection. If crossed pairs of screws are used in timber-to-timber connections, n is the number of crossed pairs of screws.

k_{ax} Factor, taking into account the angle α between screw axis and grain direction

$$k_{ax} = 1.0 \quad \text{for } 45^\circ \leq \alpha \leq 90^\circ$$

$$k_{ax} = 0.3 + \frac{0.7 \cdot \alpha}{45^\circ} \quad \text{for } 15^\circ \leq \alpha < 45^\circ \quad (2.7)$$

Equation (2.7) may be used for angles α between screw axis and grain direction $0^\circ \leq \alpha < 15^\circ$ if the following requirements are fulfilled:

1. The screws are inserted in solid timber, glued laminated timber, glued solid timber or laminated veneer lumber made from softwood.
2. The penetration length of the threaded part of the screws is

$$l_{ef,req} = \min \left\{ \begin{array}{l} \frac{4 \cdot d}{\sin \alpha} \\ 20 \cdot d \end{array} \right.$$

3. At least four screws are used in a connection.

$f_{ax,k}$ Characteristic withdrawal parameter at an angle $\alpha = 90^\circ$ based on a characteristic density of the wood-based member ρ_k of 350 kg/m^3

$$f_{ax,k} = 11.8 \text{ N/mm}^2.$$

The characteristic withdrawal parameter is also valid for softwood layers of cross-laminated timber.

ρ_k Characteristic density of the wood-based member, for LVL $\rho_k \leq 500 \text{ kg/m}^3$

For screws penetrating more than one layer of cross-laminated timber the different layers may be taken into account proportionally. In the lateral surfaces of the cross-laminated timber the screws shall be fully inserted in one layer.

HECO-UNIX-plus and HECO-UNIX-top screws	Annex 2
Characteristic load-bearing capacity values	

A.2.3.2 Head pull-through capacity

The characteristic head pull-through capacity in solid timber, glued laminated timber, cross laminated timber, laminated veneer lumber members and wood-based panels shall be calculated as:

$$F_{ax,\alpha,Rk} = n_{ef} \cdot f_{head,k} \cdot d_h^2 \cdot \left(\frac{\rho_k}{350} \right)^{0,8} \quad [N] \quad (2.8)$$

where:

$F_{ax,\alpha,Rk}$ Characteristic head pull-through capacity of the connection at an angle $\alpha \geq 30^\circ$ to the grain [N]

n_{ef} Effective number of screws according to EN 1995-1-1:2008, clause 8.7.2 (8)

For inclined screws with an angle between shear plane and screw axis $30^\circ \leq \alpha \leq 60^\circ$:

$$n_{ef} = \max \{ n^{0,9}; 0,9 \cdot n \}$$

For inclined screws as fasteners in mechanically jointed beams or columns or for the fixing of thermal insulation material, $n_{ef} = n$.

n Number of screws acting together in a connection. If crossed pairs of screws are used in timber-to-timber connections, n is the number of crossed pairs of screws.

$f_{head,k}$ Characteristic head pull-through parameter of the screw [N/mm²]

d_h Diameter of the screw head [mm]

ρ_k Characteristic density of the wood-based member or of the wood-based panel [kg/m³], for wood-based panels $\rho_k \leq 380$ kg/m³, for LVL $\rho_k \leq 500$ kg/m³

Characteristic head pull-through parameter for HECO-UNIX-plus and HECO-UNIX-top screws in connections with softwood timber for a characteristic density of 350 kg/m³ of the timber and for wood-based panels like

- Plywood according to EN 636 and EN 13986
- Oriented strand board, OSB according to EN 300 and EN 13986
- Particleboard according to EN 312 and EN 13986
- Fibreboards according to EN 622-2, EN 622-3 and EN 13986
- Cement-bonded particle boards according to EN 634-2 and EN 13986,
- Solid-wood panels according to EN 13353 and EN 13986.

with a thickness of more than 20 mm is

$$f_{head,k} = 13.0 \text{ N/mm}^2.$$

For wood based panels with a thickness $12 \text{ mm} \leq t \leq 20 \text{ mm}$ the characteristic value of the head pull-through parameter for HECO-UNIX-plus and HECO-UNIX-top screws is:

$$f_{head,k} = 8.0 \text{ N/mm}^2$$

For wood based panels with a thickness of less than 12 mm the characteristic head pull-through capacity for the screws shall be based on a characteristic value of the head pull-through parameter of 8 N/mm², and limited to 400 N complying with the minimum thickness of the wood based panels of 1.2·d, with d as outer thread diameter and the values in Table A.2.2.

HECO-UNIX-plus and HECO-UNIX-top screws	Annex 2
Characteristic values of the load-carrying capacities	

Table A.2.2 Minimum thickness of wood based panels

Wood based panel	Minimum thickness [mm]
Plywood	6
Fibreboards (hardboards and medium boards)	6
Oriented Strand Boards, OSB	8
Particleboards	8
Cement-bonded particle board	8
Solid wood Panels	12

For HECO-UNIX-plus and HECO-UNIX-top screws with a full thread the withdrawal capacity of the thread in the wood-based member with the screw head may be taken into account instead of the head pull-through capacity. The minimum penetration length of the thread of $4 \cdot d$ shall be considered in the timber member near the screw head.

In steel-to-timber connections the head pull-through capacity is not governing.

A.2.4 Spacing, end and edge distances of the screws and minimum thickness of the wood based material

Minimum thickness for structural wood-based members made from solid timber, glued laminated timber, glued solid timber, laminated veneer lumber and cross-laminated timber is $t = 24 \text{ mm}$.

A.2.4.1 Laterally and/or axially loaded screws

Screws in pre-drilled holes

For HECO screws in pre-drilled holes the minimum spacing, end and edge distances are given in EN 1995-1-1:2004+A1: 2008, clause 8.3.1.2 and Table 8.2 as for nails in pre-drilled holes. Here, the outer thread diameter d shall be considered.

Screws in non pre-drilled holes

For HECO screws in non pre-drilled holes minimum spacing and distances are given in EN 1995-1-1:2004+A1: 2008, clause 8.3.1.2 and Table 8.2 as for nails in non-predrilled holes. Here, the outer thread diameter d shall be considered.

For Douglas fir members minimum spacing and distances parallel to the grain shall be increased by 50%.

Minimum distances from the unloaded edge perpendicular to the grain may be reduced to $3 \cdot d$ also for timber thickness $t < 5 \cdot d$, if the spacing parallel to the grain and the end distance is at least $25 \cdot d$.

A.2.4.2 Only axially loaded screws

For HECO-UNIX-plus and HECO-UNIX-top screws the minimum spacing, end and edge distances are given in EN 1995-1-1:2004+A1: 2008, clause 8.7.2 and Table 8.6.

A.2.5 Insertion moment

The ratio between the characteristic torsional strength $f_{\text{tor},k}$ and the mean value of insertion moment $R_{\text{tor,mean}}$ fulfills the requirement for all screws.

HECO-UNIX-plus and HECO-UNIX-top screws	Annex 2
Characteristic load-bearing capacity values, spacings	

A.2.6 Durability against corrosion

Screws made from carbon steel may have the coatings according to Table A.2.3

Table A.2.3 Coatings of the screws

Coating		Thickness of the coating [μm]
electrogalvanised	blue chromated	4 - 10
	yellow chromated	
	black chromated	
	olive chromated	
zinc-nickel coating, galvanic clad, chromated		8 - 12
zinc flake basecoat		12 - 18

Steel no. 1.4567 is used for screws made from stainless steel.
Contact corrosion shall be avoided.

HECO-UNIX-plus and HECO-UNIX-top screws	Annex 2
Durability against corrosion	

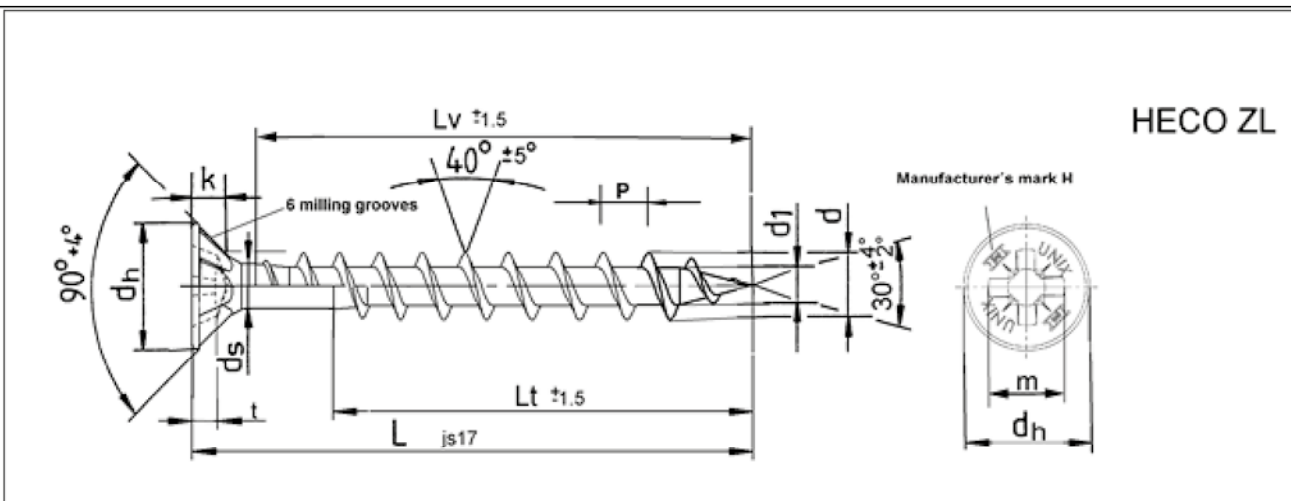

HECO ZL

Nom. Diameter		Ø 3,5	Ø 4,0	Ø 4,5	Ø 5,0	Ø 6,0									
d	upper tol. lower tol.	3,5 ^{+0,3} -0,1	4,0 ^{+0,3} -0,1	4,5 ^{+0,3} -0,1	5,0 ^{+0,3} -0,1	6,0 ^{+0,3} -0,1									
d_1	upper tol. lower tol.	2,35 2,15	2,6 2,4	2,9 2,7	3,2 3,0	4,15 3,8									
d_h	upper tol. lower tol.	6,9 ^{+0,1} -0,4	7,9 ^{+0,1} -0,4	8,9 ^{+0,1} -0,4	9,6 ^{+0,1} -0,4	11,7 ^{+0,1} -0,4									
d_s	upper tol. lower tol.					4,45 4,2									
P		Variable thread pitch													
k	upper tol. lower tol.	2,1 1,8	2,5 2,1	2,7 2,3	3,0 2,6	3,6 3,1									
Recess Z		2	2	2	2	3									
t	upper tol. lower tol.	2,15 1,7	2,6 2,05	3,15 2,65	3,6 3,0	3,6 3,0									
m		4,0	4,4	4,9	5,3	6,6									
L		L_v	L_t	L_v	L_t	L_v	L_t	L_v	L_t	L_v	L_t	L_v	L_t	L_v	L_t
20		16													
25		21		21		21		20							
30		26		26		26		25		24					
35		31		31		31		30		29					
40		36		36		36		35		34					
45		41		41		41		40		39					
50		46		46		46		45		44					
55				51		51		50		49					
60				56		56		55		54					
65				61		61		60		59					
70				66		66		65		64					
75						71		70		69					
80						76		75		74					
90								85		84					
100								95		94					
110								105		104					
120								115		114					
130														80	
140														80	
150														80	
160														80	
180														80	
190														80	
200														80	

Other screw lengths with $L_{min} \leq L \leq L_{max}$ and other thread lengths $l_g \geq 4 \cdot d$ up to max. standard thread length, are allowed

HECO-UNIX-plus and HECO-UNIX-top screws

HECO-UNIX-plus Countersunk Head, Pozi-Drive, carbon steel

Annex 3.1

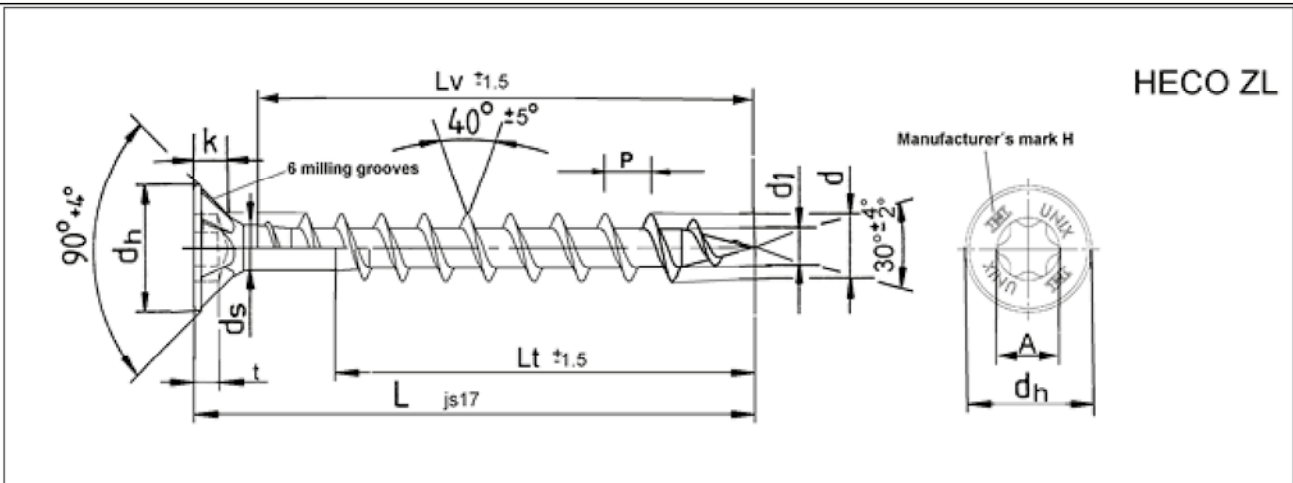

Nom. Diameter		Ø 3,5	Ø 4,0	Ø 4,5	Ø 5,0	Ø 6,0									
d	upper tol.	3,5	4,0	4,5	5,0	6,0									
	lower tol.	+0,3 -0,1	+0,3 -0,1	+0,3 -0,1	+0,3 -0,1	+0,3 -0,1									
d1	upper tol.	2,35	2,6	2,9	3,2	4,2									
	lower tol.	2,15	2,4	2,7	3,0	3,8									
dh	upper tol.	6,9	7,9	8,9	9,6	11,7									
	lower tol.	+0,1 -0,4	+0,1 -0,4	+0,1 -0,4	+0,1 -0,4	+0,1 -0,4									
ds	upper tol.					4,5									
	lower tol.					4,3									
P		Variable thread pitch													
k	upper tol.	2,1	2,5	2,7	3,0	3,6									
	lower tol.	1,8	2,1	2,3	2,6	3,1									
Recess		HD/T-15	HD/T-20	HD/T-20	HD/T-25	HD/T-30									
t	upper tol.	1,6	1,55	1,55	2,25	2,5									
	lower tol.	1,3	1,25	1,25	1,85	2,1									
A		3,35	3,94	3,94	4,53	5,63									
L	Lv														
	Lt														
20	16		16				15								
25	21		21		21		20								
30	26		26		26		25		24						
35	31		31		31		30		29						
40	36		36		36		35		34						
45	41		41		41		40		39						
50	46		46		46		45		44						
55			51		51		50		49						
60			56		56		55		54						
65			61		61		60		59						
70			66		66		65		64						
75					71		70		69						
80					76		75		74						
90							85		84						
100							95		94						
110							105		104						
120							115		114						
130											80				
140			Lv without shank ribs									80			
150											80				
160											80				
180											80				
190											80				
200											80				

Other screw lengths with $L_{min} \leq L \leq L_{max}$ and other thread lengths $l_g \geq 4 \cdot d$ up to max. standard thread length, are allowed

HECO-UNIX-plus and HECO-UNIX-top screws

HECO-UNIX-plus Countersunk Head, T-Drive, carbon steel

Annex 3.2

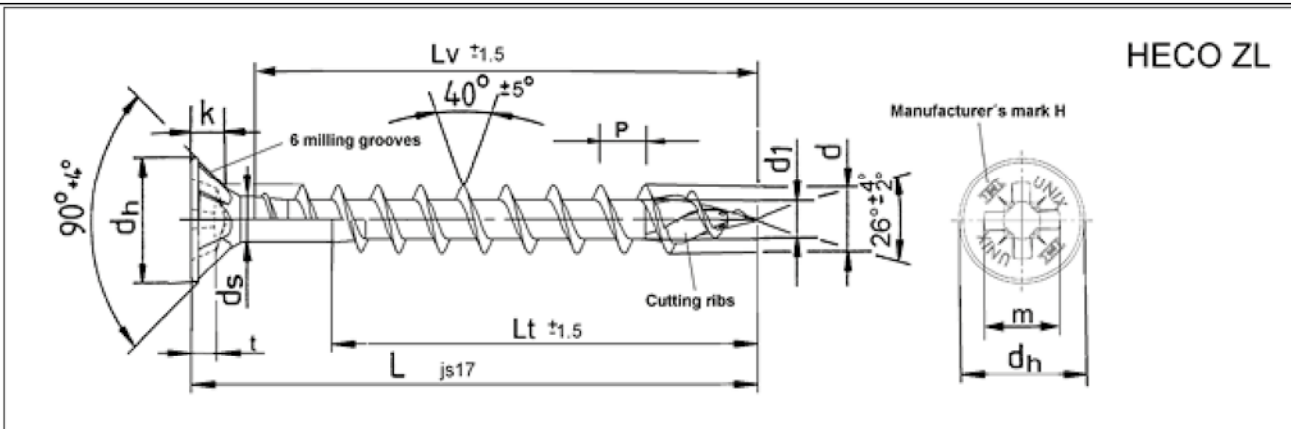

Nom. diameter		Ø 3,5	Ø 4,0	Ø 4,5	Ø 5,0	Ø 6,0			
d	upper tol.	3,5 ^{+0,3}	4,0 ^{+0,3}	4,5 ^{+0,3}	5,0 ^{+0,3}	6,0 ^{+0,3}			
	lower tol.	-0,1	-0,1	-0,1	-0,1	-0,1			
d₁	upper tol.	2,35	2,65	2,9	3,2	4,1			
	lower tol.	2,15	2,45	2,7	3,0	3,8			
d_h	upper tol.	6,9 ^{+0,1}	7,9 ^{+0,1}	8,9 ^{+0,1}	9,6 ^{+0,1}	11,7 ^{+0,1}			
	lower tol.	-0,4	-0,4	-0,4	-0,4	-0,4			
d_s	upper tol.					4,4			
	lower tol.					4,2			
P		Variable thread pitch							
k	upper tol.	2,1	2,5	2,7	3,0	3,6			
	lower tol.	1,8	2,1	2,3	2,6	3,1			
Recess Z		2	2	2	2	3			
t	upper tol.	2,15	2,6	3,15	3,6	3,6			
	lower tol.	1,7	2,05	2,65	3,0	3,0			
m		4,0	4,4	4,9	5,3	6,6			
L	L_v	L_t	L_v	L_t	L_v	L_t	L_v	L_t	
20	16								
25	21		21						
30	26		26		26	25			
35	31		31		31	30			
40	36		36		36	35	35		
45	41		41		41	40	40		
50	46		46		46	45	45		
55			51		51	50	50		
60			56		56	55	55		
65			61		61	60	60		
70			66		66	65	65		
75			71		71	70	65		
80			76		76	75	65		
90						85	85		
100						95	95		
110						105	105		
120						115	115		
130							125		
140			L _v without shank ribs					135	
150							145		
160							155		
180								80	
190								80	
200								80	
220								80	
240								80	
260								80	
280								80	
300								80	

Other screw lengths with $L_{min} \leq L \leq L_{max}$ and other thread lengths $l_g \geq 4 \cdot d$ up to max. standard thread length, are allowed

HECO-UNIX-plus and HECO-UNIX-top screws

HECO-UNIX-top Countersunk Head, Pozi-Drive, carbon steel

Annex 3.3

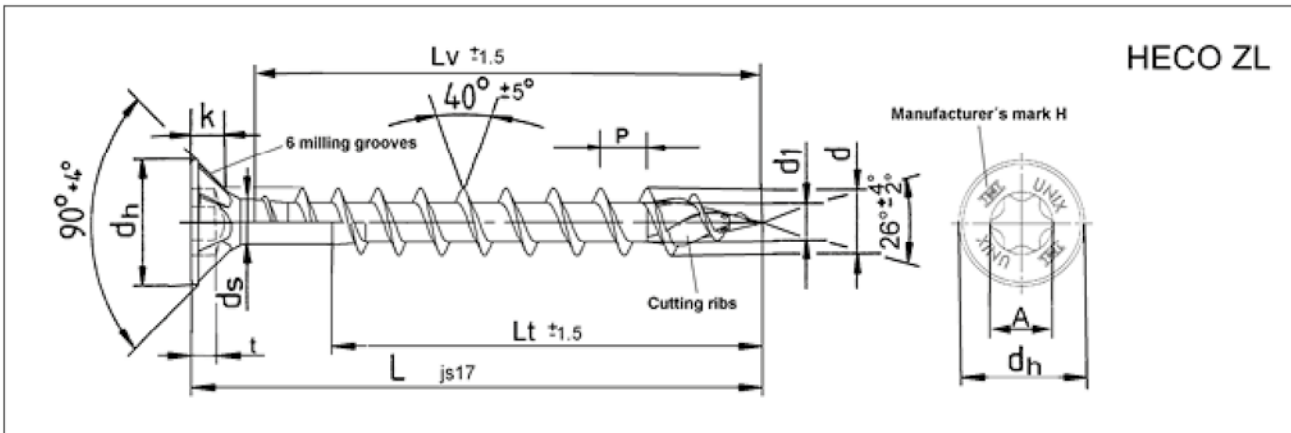

Nom. diameter		Ø 3,5	Ø 4,0	Ø 4,5	Ø 5,0	Ø 6,0			
d	upper tol.	3,5 +0,3	4,0 +0,3	4,5 +0,3	5,0 +0,3	6,0 +0,3			
	lower tol.	-0,1	-0,1	-0,1	-0,1	-0,1			
d1	upper tol.	2,35	2,65	2,9	3,2	4,1			
	lower tol.	2,15	2,45	2,7	3,0	3,8			
dh	upper tol.	6,9 +0,1	7,9 +0,1	8,9 +0,1	9,6 +0,1	11,7 +0,1			
	lower tol.	-0,4	-0,4	-0,4	-0,4	-0,4			
ds	upper tol.					4,4			
	lower tol.					4,2			
P		Variable thread pitch							
k	upper tol.	2,1	2,5	2,7	3,0	3,6			
	lower tol.	1,8	2,1	2,3	2,6	3,1			
Recess		HD/T-15	HD/T-20	HD/T-25	HD/T-25	HD/T-30			
t	upper tol.	1,6	1,55	1,9	2,25	2,5			
	lower tol.	1,3	1,25	1,5	1,85	2,1			
A		3,35	3,94	4,53	4,53	5,63			
L	Lv								
	Lt								
20	Lv	16							
25	Lv	21	21						
30	Lv	26	26	26	25				
35	Lv	31	31	31	30				
40	Lv	36	36	36	35	35			
45	Lv	41	41	41	40	40			
50	Lv	46	46	46	45	45			
55	Lv		51	51	50	50			
60	Lv		56	56	55	55			
65	Lv		61	61	60	60			
70	Lv		66	66	65	65			
75	Lv		71	71	70	65			
80	Lv		76	76	75	65			
90	Lv				85	85			
100	Lv				95	95			
110	Lv				105	105			
120	Lv				115	115			
130	Lv					125			
140	Lv					135			
150	Lv					145			
160	Lv					155			
180	Lv						80		
190	Lv						80		
200	Lv						80		
220	Lv						80		
240	Lv						80		
260	Lv						80		
280	Lv						80		
300	Lv						80		

Other screw lengths with $L_{min} \leq L \leq L_{max}$ and other thread lengths $l_g \geq 4 \cdot d$ up to max. standard thread length, are allowed

HECO-UNIX-plus and HECO-UNIX-top screws

HECO-UNIX-top Countersunk Head, T-Drive, carbon steel

Annex 3.4

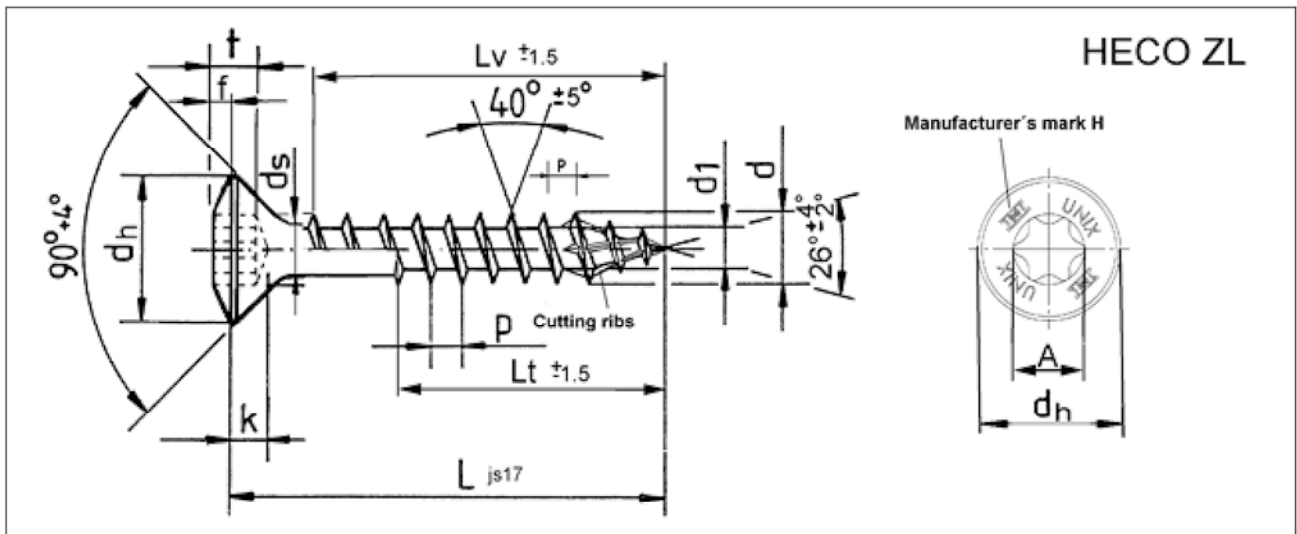

Nom. diameter	Ø 3,5	Ø 4,0	Ø 4,5	Ø 5,0	Ø 6,0										
d	upper tol. lower tol.			4,5 ^{+0,3} -0,1	5,0 ^{+0,3} -0,1										
d_1	upper tol. lower tol.			3,25 3,0	3,65 3,45										
d_h	upper tol. lower tol.			7,2 ^{+0,1} -0,4	7,2 ^{+0,1} -0,4										
d_s	upper tol. lower tol.			3,35	3,9										
P	Variable thread pitch														
k	upper tol. lower tol.			2,35 1,95	2,05 1,65										
Recess				HD/T-20	HD/T-20										
t	upper tol. lower tol.			1,7 1,4	1,7 1,4										
A				3,94	3,94										
L		L_v	L_t	L_v	L_t	L_v	L_t	L_v	L_t	L_v	L_t	L_v	L_t	L_v	L_t
20															
25															
30															
35															
40						36	36								
45						41	41								
50						46	46								
55						51	51								
60						56	56								
65						61	61								
70						66	66								
75						71	71								
80						76	76								
L_v without shank ribs															

Other screw lengths with $L_{min} \leq L \leq L_{max}$ and other thread lengths $l_g \geq 4 \cdot d$ up to max. standard thread length, are allowed

HECO-UNIX-plus and HECO-UNIX-top screws

HECO-UNIX-top cladding screw with raised Countersunk Head, T-Drive, stainless steel

Annex 3.5

English translation prepared by DIBt

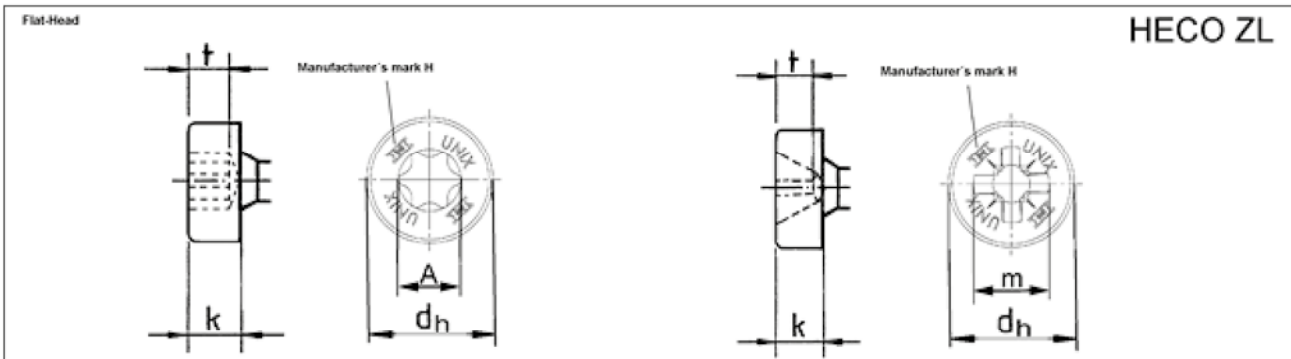

Cylinder head			Recess									
Nom. diameter	d_h	$\begin{matrix} +Tol \\ -Tol \end{matrix}$	k	$\begin{matrix} +Tol \\ -Tol \end{matrix}$	HD/T-Drive	t	$\begin{matrix} +Tol \\ -Tol \end{matrix}$	A	PZ-Drive	t	$\begin{matrix} +Tol \\ -Tol \end{matrix}$	m
3,5	6,5	+0	2,7	2,7	HD/T-15	1,85	1,85	3,35	2	1,85	1,85	3,8
		-0,4										
4,0	7,0	+0,2	2,9	2,9	HD/T-20	2,0	2,0	3,94	2	2,46	2,46	4,4
		-0,2										
4,5	8,0	+0	3,7	3,7	HD/T-25	2,72	2,72	4,53	2	2,72	2,72	4,6
		-0,5										
5,0	8,0	+0	3,7	3,7	HD/T-25	2,72	2,72	4,53	2	3,15	3,15	5,1
		-0,5										
6,0	9,0	+0,3	4,2	4,2	HD/T-30	3,0	3,0	5,63	3	3,48	3,48	6,7
		-0,3										

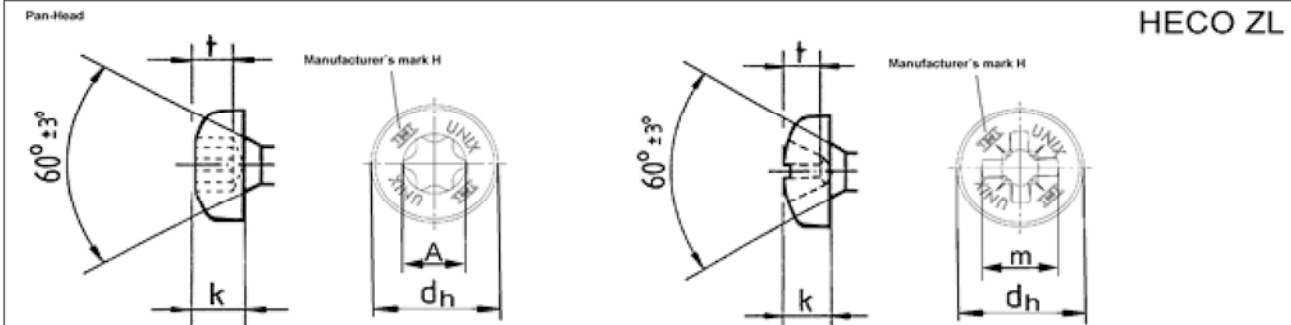

Pan head			Recess									
Nom. diameter	d_h	$\begin{matrix} +Tol \\ -Tol \end{matrix}$	k	$\begin{matrix} +Tol \\ -Tol \end{matrix}$	T-Drive	t	$\begin{matrix} +Tol \\ -Tol \end{matrix}$	A	PZ-Drive	t	$\begin{matrix} +Tol \\ -Tol \end{matrix}$	m
3,5	7,0	+0	2,6	2,6	HD/T-15	1,85	1,85	3,35	2	1,85	1,85	3,8
		-0,4										
4,0	8,0	+0	2,9	2,9	HD/T-20	2,0	2,0	3,94	2	2,46	2,46	4,4
		-0,5										
4,5	9,0	+0	3,05	3,05	HD/T-25	2,72	2,72	4,53	2	2,72	2,72	4,6
		-0,5										
5,0	9,7	+0	3,4	3,4	HD/T-25	2,72	2,72	4,53	2	3,15	3,15	5,1
		-0,5										
6,0	11,8	+0	4,0	4,0	HD/T-30	3,5	3,5	5,63	3	3,48	3,48	6,7
		-0,6										

HECO-UNIX-plus and HECO-UNIX-top screws

HECO-UNIX Head-Types, carbon steel / stainless steel

Annex 3.7